

FlexiTank™

Assembly Instructions

SEE REVERSE FOR FLEXITANK ADVICE, REPAIR GUIDANCE, AND HANDY TIPS

Contents 25 & 50L / 6.6 & 13 gal:

- 1x 16mm / 1/2" Tap
- 1x FlexiTank
- 4x Support Poles
- 1x Repair Kit

Contents 100L / 25 gal:

- 1x 16mm / 1/2" Tap
- 1x FlexiTank
- 5x Support Poles
- 1x 16mm / 1/2" Click-Fit Connector
- 1x 16mm / 1/2" Blanking Cap
- 1x Repair Kit

Contents 225L & 400L / 60 & 105 gal:

- 1x 16mm / 1/2" Tap
- 1x FlexiTank
- 6x Support Poles
- 1x 16mm / 1/2" Click-Fit Connector
- 1x 16mm / 1/2" Blanking Cap
- 1x Repair Kit

Contents 750L & 1000L / 200 & 265 gal:

- 1x 16mm / 1/2" Tap
- 1x FlexiTank
- 9x Support Poles (750L) / 11x (1000L)
- 1x 16mm / 1/2" Click-Fit Connector
- 1x 16mm / 1/2" Blanking Cap
- 1x Support Band
- 1x Repair Kit

IMPORTANT! IF USING ON A SYSTEM OF 6 POTS OR MORE ENSURE YOU RAISE THE FLEXITANK BY AT LEAST 150MM / 6" ABOVE YOUR HIGHEST POT - DO THIS BEFORE FILLING

1



Remove contents, ensure all parts are correct and in good order.

2

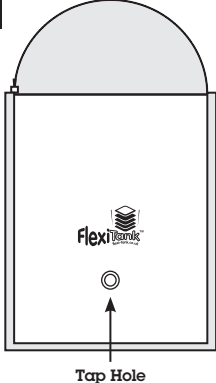

Tap Hole

Undo the FlexiTank zip and open the FlexiTank tank up - logo outside. Locate the Tap Hole towards the base.

3

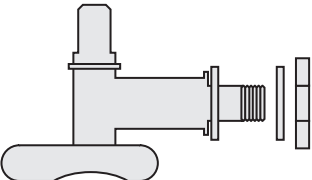

To fit the tap into the Tap Hole first take the tap, remove the nut and ONE washer from the tap thread.

4 NEVER USE THE OTHER FITTINGS IN THE HOLE TOWARDS BASE!

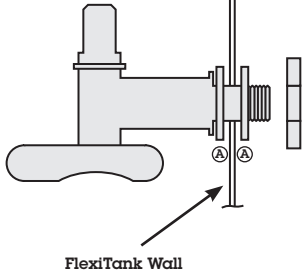

FlexiTank Wall

Push the tap through the FlexiTank, fitting the rubber washers as shown (A). Fit the tap upside down tightening as far as you can by hand.

5

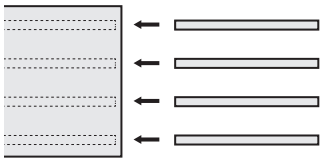

25L / 6.6 gal: 4 Poles
50L / 13 gal: 4 Poles
100L / 25 gal: 5 Poles
225L / 60 gal: 6 Poles
400L / 105 gal: 6 Poles
750L / 200 gal: 9 Poles
1000L / 265 gal: 11 Poles

Carefully insert the Support Poles into the sleeves on the FlexiTank.

6

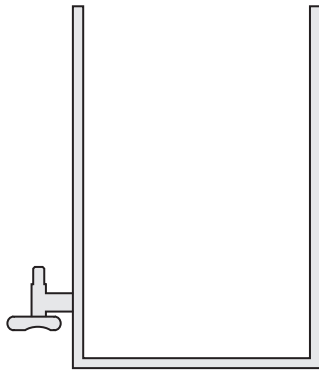

Stand the tank upright, ensuring it is on a flat, smooth surface, free from debris.

7 750L & 1000L / 200 & 265 gal FlexiTanks ONLY!

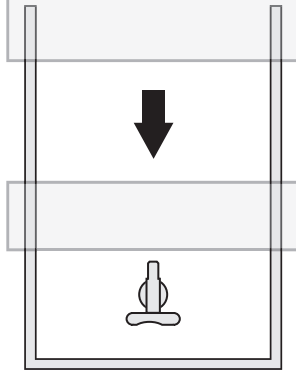

Place Support Band around the FlexiTank BEFORE filling. Slide band down so that it is positioned just above the tap.

8

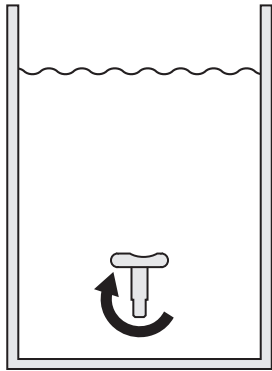

Fill the Flexitank. Once full, twist the tap 180° clockwise to the correct position. If using Support Band ensure that it remains level whilst filling.

DO NOT MOVE THE FLEXITANK WHEN IT HAS WATER IN IT. THE FLEXITANK MUST BE COMPLETELY DRAINED BEFORE MOVING. FAILURE TO DO SO WILL VOID YOUR WARRANTY.

For US enquiries please contact (702) 338-0373 / info@autopot-usa.com

For UK/RoW enquiries please contact +44 (0)1276 534900 / mail@autopot.co.uk

SEE REVERSE FOR FLEXITANK CONTENTS AND ASSEMBLY INSTRUCTIONS

POSITIONING

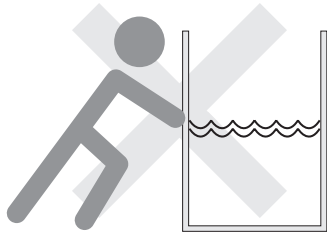

Never attempt to drag or otherwise move a FlexiTank when in use, regardless of the fill level. Get your FlexiTank correctly positioned before filling.

ELEVATION

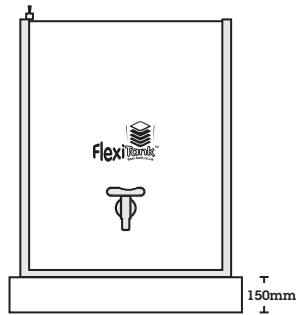

If using with a gravity fed system always raise your FlexiTank to a minimum of 150mm / 6" above the highest module.

FILL LEVEL

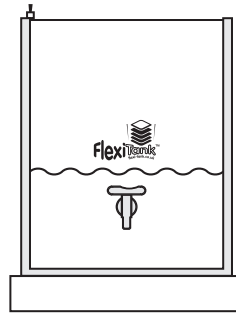

Refill the FlexiTank when there is approx 1/3 of the solution left. NEVER ALLOW THE FLEXITANK TO RUN EMPTY.

REFILLING

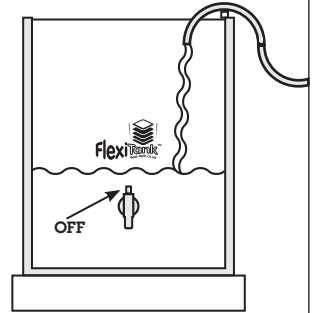

When refilling the FlexiTank turn the tap off. Refill and leave for 60 mins before turning back on. This prevents sediment being pulled through pipes whilst refilling.

FILTERS

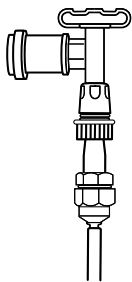

Always use a filter with your FlexiTank. Check your filter once a week and clean if necessary - especially if using organics / if in a poor water area.

FILTERS

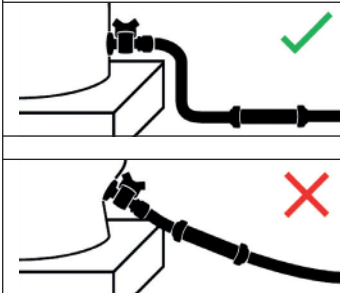

When elevating your FlexiTank on a stand, install your in-line filter away from the FlexiTank tap to prevent tension against the FlexiTank.

AIR STONES



Do not place an air stone in the FlexiTank as this can raise pH levels of the nutrient solution. A water pump may be used to agitate the solution but is not necessary.

WATER TEMPERATURES

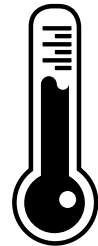

18 - 21°C / 64.5 - 70°F

Generally your FlexiTank is best positioned outside the growing area. Aim for a water temperature of between 18 and 21°C in the FlexiTank

IMPORTANT! ALL REPAIRS ARE THE SOLE RESPONSIBILITY OF THE USER - FOR WARRANTY ENQUIRIES CONTACT YOUR POINT OF PURCHASE

REPAIR - STEP 1

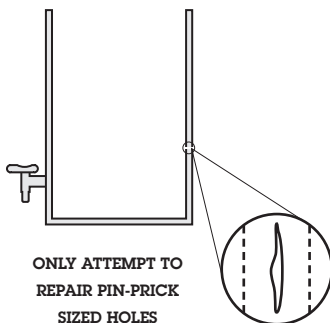

ONLY ATTEMPT TO REPAIR PIN-PRICK SIZED HOLES

Upon detecting a hole empty the FlexiTank immediately. Disconnect the FlexiTank. Dry the FlexiTank using cloth etc.

REPAIR - STEP 2

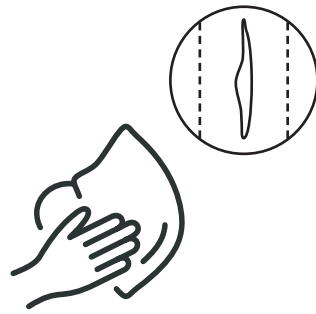

Ensure the inside of the FlexiTank is clean and dry - YOU WILL BE APPLYING YOUR PATCH TO THE INSIDE SURFACE.

REPAIR - STEP 3

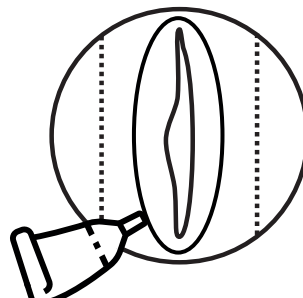

Apply adhesive to the area around the hole on the inside of the FlexiTank itself.

REPAIR - STEP 4

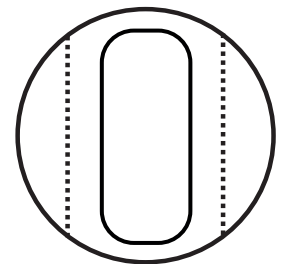

Apply the patch to the FlexiTank. Allow 12 hours before refilling the FlexiTank.

For US enquiries please contact (702) 338-0373 / info@autopot-usa.com

For UK/RoW enquiries please contact +44 (0)1276 534900 / mail@autopot.co.uk